

SUITABLE FOR THESE USES:	
<input checked="" type="checkbox"/>	INDUSTRIAL APPLICATIONS
<input checked="" type="checkbox"/>	MUNICIPAL APPLICATIONS

HVT-PI Halmi Plastic Insert Venturi

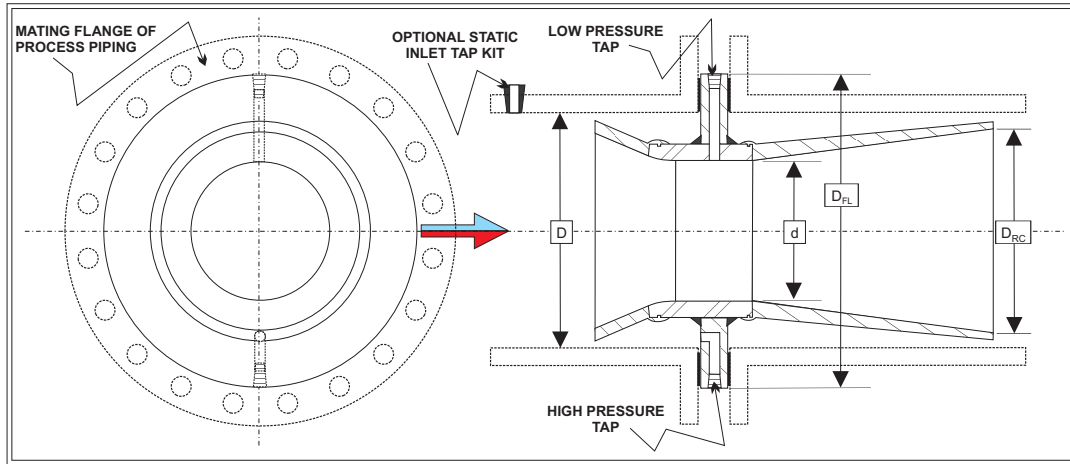

- General Features:**
- ▶ High Accuracy, Reliability
 - ▶ Low Permanent Pressure Loss
 - ▶ Low Installed Cost
 - ▶ Long Service Life (Up to 15 year warranty)
 - ▶ Unaffected by downstream piping
 - ▶ Custom designed for specific application
 - ▶ Bi-Directional designs are available
 - ▶ Field verifiable
 - ▶ Prompt, reliable response to your technical inquiries
 - ▶ Total Support from Design through Installation and Beyond

GENERAL DESCRIPTION:

The HVT-PI, Halmi Plastic Insert Type Venturi primary flow element is a high quality, high accuracy and reliability differential producing flow measurement device that is thoroughly substantiated for 2 sigma performance. This equipment differs from the HVT pressure vessel meter design in that the hydraulic shape is ruggedly constructed on a properly sized center flange that fits within the bolt circle of the mating process piping. Thus the insert (center flange) is captured between the mating pipe flanges and does not need to intrinsically withstand the line pressure in the process piping, resulting in an effective pressure rating of the element matching that of the process piping identically. This feature coupled with the economy of fiberglass permits substantial design and manufacturing cost savings without sacrificing accuracy and reliability. Static Inlet tap and Grouted-In designs for larger line sizes, as well as special HVT-DG models fitted with high and low pressure tap vent cleaners to allow clearing the piezometer taps from buildups in susceptible line fluids are available. Please ask for details.

APPLICATIONS:

The HVT-PI, Halmi Plastic Insert Type Venturi primary flow element is designed to measure full pipe liquids or clean gasses over limited temperature and/or wide pressure ranges. Advantaged by minimum cost, weight, permanent pressure loss and laying length with maximum accuracy, repeatability, reliability and performance substantiation (to 2 sigma.), typical applications include potable water, combustion air, compressor surge control, oxygen & nitrogen measurement for air separation plants, and flow rate control applications when close coupled to butterfly valve.

MATERIALS OF CONSTRUCTION:

The HVT-PI is differentiated from other insert meter types offered by PFS, Inc., by virtue of the fact that the entrance and exit cones of the HVT-PI are manufactured using Fiberglass reinforced polyester resin. The center flange is generally provided in carbon steel coated with epoxy appropriate for the particular service intended for the meter while the throat section encompassing the beginning of the exit divergent angle as well as the end of the entrance convergent angle and entrance radius blend leading to the throat are typically 304 stainless steel. Depending upon the intended service, the typical material selection can be modified to suit.

DESIGN AND MANUFACTURING STANDARDS:

- All materials are mill certified and of first quality.
- All applicable codes and standards are considered such as section 8 of the Boiler and Pressure Vessel Code as well as ASME B31.1 and 31.3. ASME fluid meters, MFC-3M-1985, ISO 5167, BS-7045, compliant.
- Designed for use between raised face, flat faced, ring joint or van stone flanges of any flange rating of either U. S. or foreign standards.

©2006- Primary Flow Signal, Inc.- All Rights Reserved

PRODUCT SPECIFICATIONS:

Accuracy:

- +/- 0.50% of actual reading (2 Sigma)
- +/- 0.25% of actual reading or better based on hydraulic calibration.

Range Ability:

100:1 or more depending on secondary group capabilities and arrangement.

Operating Conditions:

Line Fluid Capability:
Gas or liquid full pipe flow.
Clean with minimal particulate contamination.

Temperature Range:

-60°F to 200°F (as limited by the materials of construction and capabilities of the associated secondary device(s) used.)

Line Pressure Capacity:

From full vacuum to the limits of the process piping.

Line Size Capability:

Unlimited line size capabilities.
Between 3" through 144" in service.

Beta Ratio Capability:

Custom sized and designed for Beta ratio range between 0.30 through 0.75.

Pipe Reynolds Number R_D Capability:

Discharge coefficient is constant above 75,000 R_D .
Discharge coefficient bias and random error between 12,000 R_D and 75,000 R_D is empirically established and highly repeatable.

Permanent Pressure Loss:

Varies from 3% of differential and up depending on application conditions, beta ratio, and exit cone truncation ratio, and can be engineered to meet your requirements

PLEASE NOTE: Use this data as general application guidance for the equipment and/or services referenced herein. Users may reasonably expect this disclosure to constitute an accurate factual representation at the time of publication, however all data and specifications contained herein are subject to change without prior notice. This is not a contractual obligation of PFS, Inc. Primary Flow Signal, Inc. is bound SOLELY by its official SUBMITTAL document when presented in connection with an actual purchase and sale transaction, which SUBMITTAL shall form the controlling representation of any product or service claimed by Primary Flow Signal, Inc.
PFS PUBLICATION #TD-1500-HVT-PI-rev02

INSTALLATION INFORMATION

Typical Installation Arrangement for HVT-Insert type Primary Flow Elements.

■ Flange Bolt Holes Must Straddle Horizontal and Vertical Centerlines.

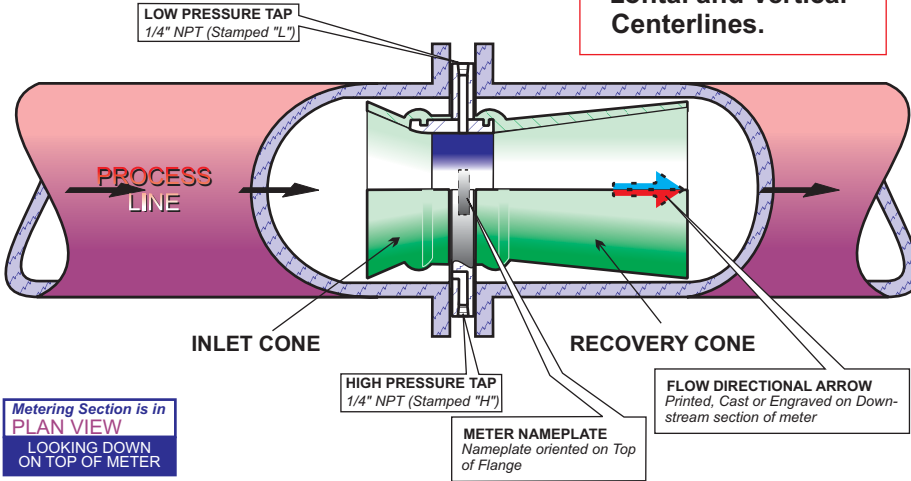

The Proper Method of Installing a Halmi Venturi Meter INSERT TYPE DESIGN

- Item 1:
This is a high quality flow meter! Handle with care during installation.
- Item 2:
Verify that the primary flow element inlet and recovery cone outside diameters are sized properly to permit adequate clearance in the process pipe line.
- Item 3:
If required, measure at least four cross sections of the upstream pipe inside diameter prior to installation, and record on data sheet for meter calibration purposes.
- Item 4:
If improperly installed, it must be reinstalled!
- Item 5:
If damaged, it must be replaced!
- Item 6:
Handle it from its outside ONLY!
- Item 7:
Do not damage its inside!

Item 8:
Install meter in the pipe line so that the *Flow Directional Arrow* agrees with the direction of the flow!

Item 9:
Make sure that the "High Pressure Port" is not covered by the gasket, or plugged in any way!

Item 10:
Center meter carefully in the process pipeline!

Item 11:
Orient Pressure Taps HORIZONTALLY!

Item 12:
Provide necessary clearances as deemed practical for installation, inspection and maintenance!

Item 13:
Tighten flange bolts according to typical industry flange assembly standards, adequate to prevent leakage from connection.

Item 14:
Tolerances should be within industry standards for these installation instructions!

Item 15:
For impulse piping recommendations please contact PFS, Inc. to obtain appropriate literature.

--- FAILURE TO FOLLOW INSTALLATION DIRECTIONS MAY VOID WARRANTY! ---

